

Unilite Opto Technology

email: info@unilite-tech.com

U-P3528R-HRF

■ Description

The PLCC2 type U-P3528R-HRF SMD LED, with its light weight and smaller than lead frame type components, enables smaller board size, higher packing density, reduced storage space and miniature applications.



- Dice Material : AlGaInP
- Light Color : Red
- Lens Color : Water Transparent

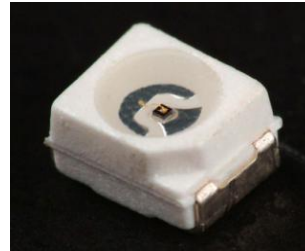

■ Features

- 1 chip package
- Compatible with automatic placement equipment
- Compatible with reflow soldering process
- Long operating life
- Low forward voltage operated
- Instant light
- Pb -free/ RoHS compliant

■ Applications

- Information boards
- Automotive Interior Lighting
- Indoor and outdoor display
- Indicator
- Backlighting
- General applications

Unilite Opto Technology

email: info@unilite-tech.com

U-P3528R-HRF

■ Outline Dimensions (mm)

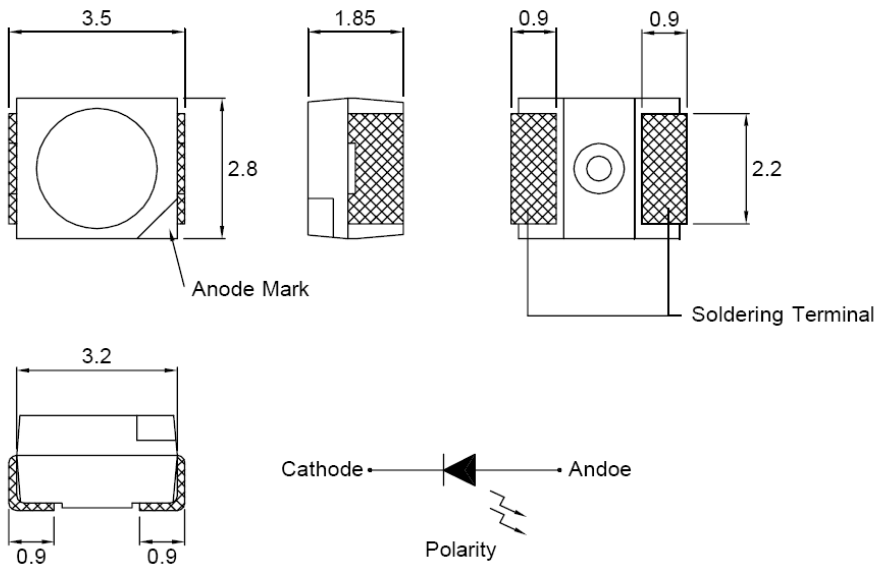

■ Recommended Soldering Pad Design

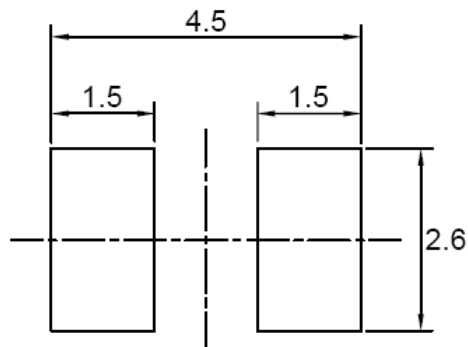

■ Part Numbering System

U - P 3 5 2 8 R - HRF

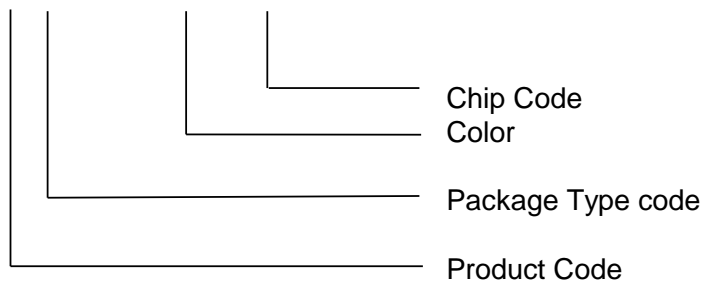

Unilite Opto Technology

email: info@unilite-tech.com

U-P3528R-HRF

■ Absolute Maximum Ratings at Ta = 25 °C

PARAMETER	MAX.	UNIT
Power Dissipation *	72	mW
Continuous Forward Current *	30	mA
Peak Forward Current (1/10 Duty Cycle , 0.1ms Pulse Width) *	60	mA
Reverse Voltage	5	V
Derating Linear From 50°C	0.4	mA/°C
Operating Temperature Range	-40 to + 100	°C
Storage Temperature Range	-40 to + 100	°C
LED Junction Temperature	125	°C
Reflow Soldering Condition 245 °C for 10 seconds (one time only)		

■ Electro-Optical Characteristics

Condition : I_F = 20mA , T_a = 25°C

PARAMETER	SYMBOL	TEST CONDITION	VALUES			UNIT
			MIN.	TYP.	MAX.	
* Forward Voltage	V _F	I _F =20mA		2.1	2.7	V
Reverse Current	I _R	V _R = 5V			100	μA
Intensity	mcd	I _F =20mA	320	440		mcd
Peak Emission Wavelength	λ _p	V _R = 20V		632		nm
Dominant Wavelength	λ _d	V _R = 20V		625		nm
Viewing Angle at 50% I _v	2θ 1/2	I _F =20mA		120		Deg.

Unilite Opto Technology

email: info@unilite-tech.com

U-P3528R-HRF

■ Bin Grade Limits ($I_F = 20 \text{ mA}^*$) Luminous Intensity / mcd

Tolerance : $\pm 15\%$

Bin	R1	R2	R3	R4	R5	R6
Min.	168	230	295	355	465	560
Max.	230	295	355	460	560	715

■ Bin Grade Limits ($I_F = 20 \text{ mA}^*$) Chromaticity Coordinates

Bin	RW1	RW2	RW3	RW4	RW5
Min.	618	622	626	630	634
Max.	622	626	630	634	638

■ Bin Grade Limits ($I_F = 20 \text{ mA}^*$) Forward Voltage

Bin	VF1	VF2	VF3
Min.	1.80	2.00	2.20
Max.	2.00	2.20	2.40

Unilite Opto Technology

email: info@unilite-tech.com

U-P3528R-HRF

■ Characteristics Data

Fig.1 Forward current vs. Forward Voltage

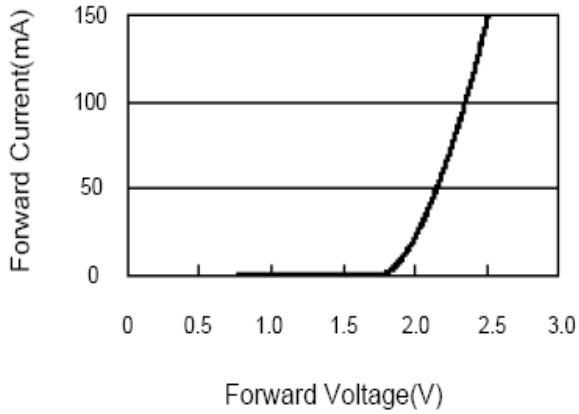

Fig.2 Luminous Intensity vs. Forward Current

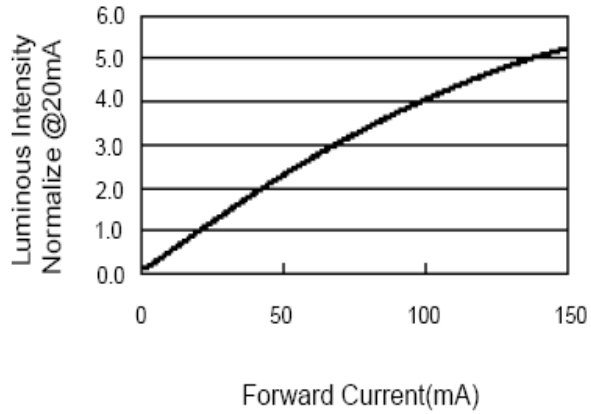

Fig.3 Forward Voltage vs. Temperature

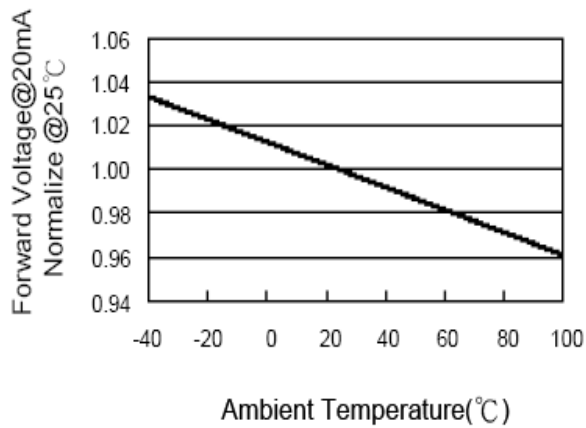

Fig.4 Luminous Intensity vs. Temperature

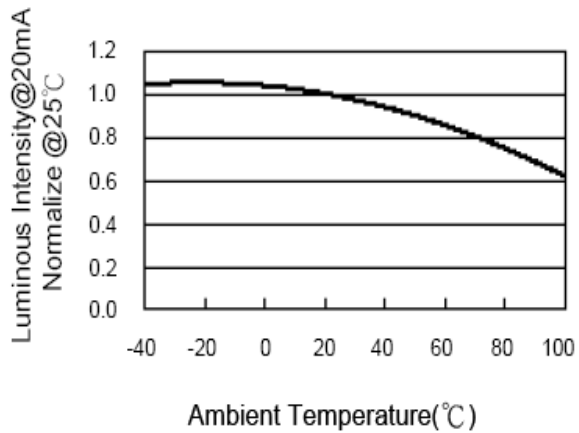

Fig.5 Relative Intensity vs. Wavelength

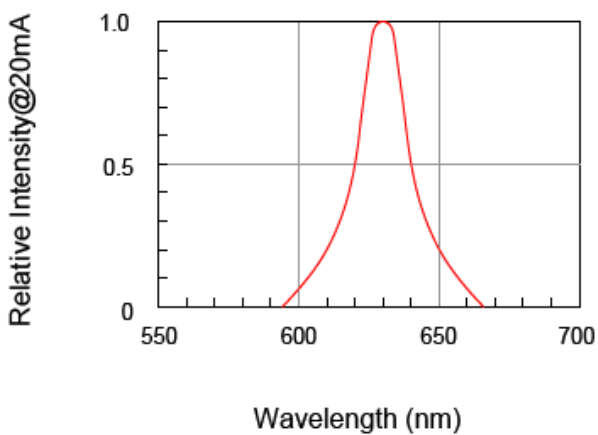
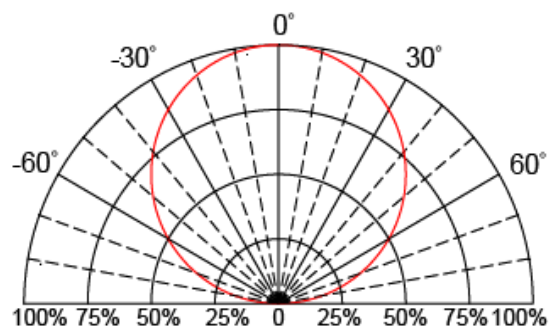

Fig.6 Directive Radiation



Unilite Opto Technology

email: info@unilite-tech.com

U-P3528R-HRF

■ Carrier Type Dimension

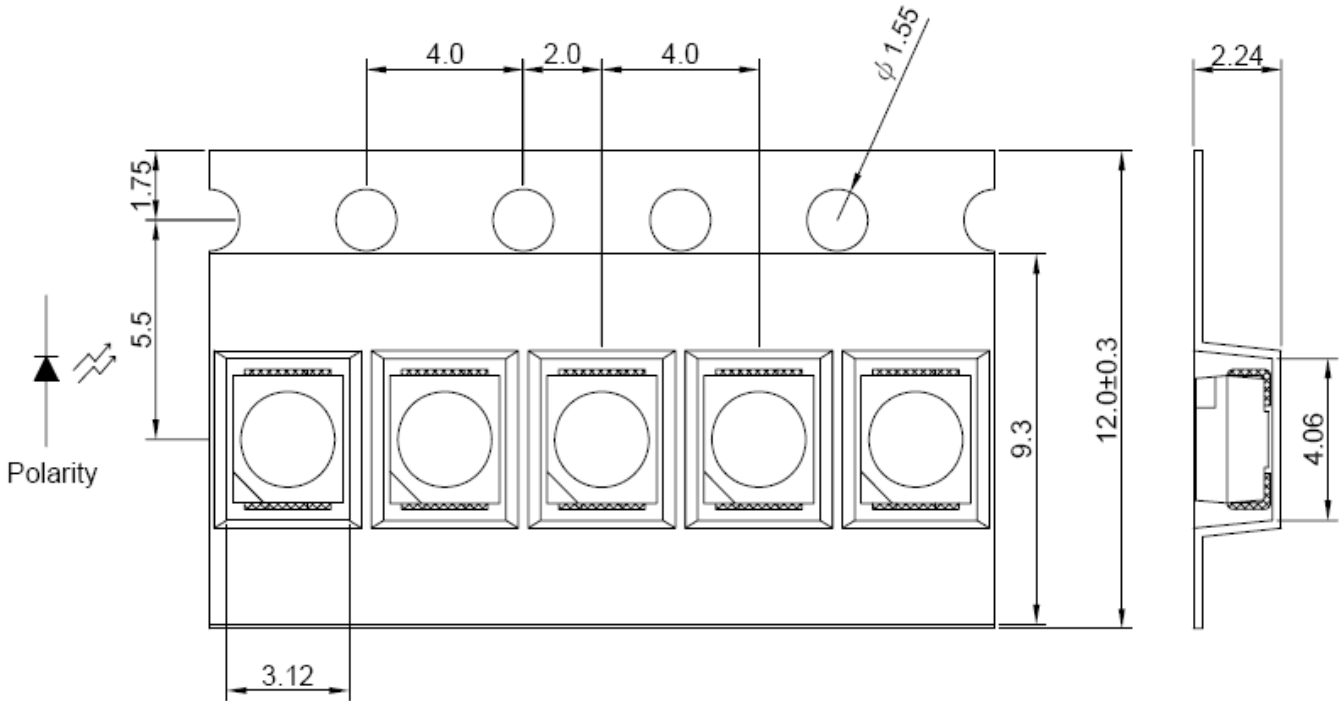

■ Reel Dimension

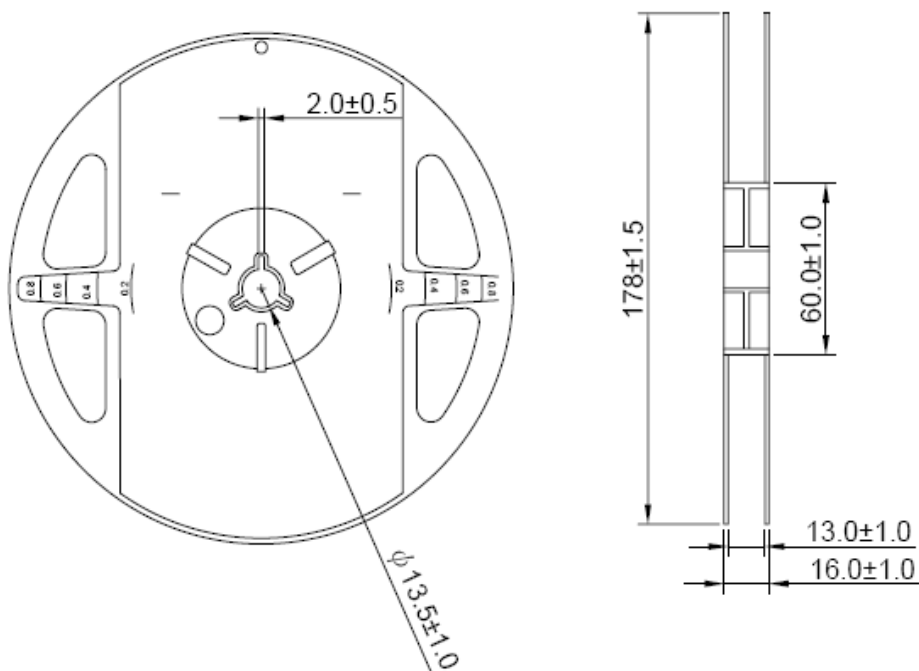

Unilite Opto Technology

email: info@unilite-tech.com

U-P3528R-HRF

■ Reliability Test Items and Conditions

(1) TEST ITEMS AND RESULTS

TEST ITEM	TEST CONDITION	ENVIRO-NMENT	QUANTITY	NUMBER OF DAMAGED
Operating Life Test MIL-STD-750:1026 MIL-STD-883:1005	Constant Current : SPEC. Max. Test Time : 1000 Hours Under Room Temperature	25±5°C	22 PCS	0/22
High Temp. Storage Test MIL-STD-883:1008	Temperature : 105±5°C Test Time : 500 Hours	25±5°C	22 PCS	0/22
Low Temp. Storage Test JIS C 7021:B-12	Temperature : -40±5°C Test Time : 500 Hours	25±5°C	22 PCS	0/22
High Temp. High Humidity Test MIL-STD-202F:103	TA : 65°C±3°C 90% -95% RH Test Time : 240 Hours	25±5°C	22 PCS	0/22
Temperature Cycling MIL-STD-883E:1010.7 MIL-STD-750:1051	105°C ~ 25°C ~ -40°C ~ 25°C 60min 10min 60min 10min TOTAL : 20 CYCLES	25±5°C	22 PCS	0/22
Thermal Shock Test MIL-STD-750:1051 MIL-STD-883:1011	105°C±5°C ~ -40°C±5°C (30min) (30min) Total : 10 Cycles	25±5°C	22 PCS	0/22

(2) CRITERIA FOR JUDGING DAMAGE

Item	Symbol	Test Conditions	Criteria for Judgement	
			Min	Max
Forward Voltage	V _F	I _F =20mA	—	U.S.L.*) x 1.2
Reverse Current	I _R	V _R =5V	—	10μA
Luminous Intensity	I _v	I _F =20mA	L.S.L.**) x 0.7	—

U.S.L.:Upper Standard Level

L.S.L.:Lower Standard Level

Unilite Opto Technology

email: info@unilite-tech.com

U-P3528R-HRF

■ Cautions

(1) Moisture Proof Package

- A) The moisture proof package, a plastic bag with a zipper, is used to keep moisture to a minimum in the package.
- B) A package of a moisture absorbent material (silica gel) is also inserted into the plastic moisture proof bag and the silica gel changes its color from blue to pink as it absorbs moisture.
- C) The absorbed moisture in the SMT package may vaporize and expand during soldering. This may cause exfoliation of the contacts and damage to the optical characteristics of the LEDs.

(2) Storage Conditions

- A) Before opening the package :
The LEDs should be kept at 30°C or less and 45~60% RH or less and should be used within a year. When storing the LEDs, moisture proof package with absorbent material (silica gel) is recommended.
- B) After opening the package :
The LEDs should be kept at 30°C or less and 55% RH or less and should be soldered within 168 hours (7days) after opening the package. The unused LEDs should be stored in moisture proof packages.
- C) It's also recommended to return the LEDs to the original moisture proof bag and to reseal the moisture proof bag again.
- D) If the moisture absorbent material (silica gel) has faded away or the SMD LEDs have exceeded the storage time, baking treatment (more than 24 hours at 65+/-5°C) should be performed before soldering.

(3) Heat Generation

- A) The thermal design of the end product is very important. It is necessary to avoid intense heat generation and operate within the maximum ratings given in this specification.
- B) The operating current should be decided after considering the ambient maximum temperature of LEDs.

(4) Cleaning

- A) Isopropyl alcohol is recommended to be used as a solvent for cleaning the LEDs.
- B) Before cleaning, a pre-test should be done to confirm whether any damage to the LEDs will occur.

Unilite Opto Technology

email: info@unilite-tech.com

U-P3528R-HRF

(5) Soldering

Reflow Soldering (recommended) :

- A) To prevent from cracking, please bake (65°C , 24hrs) before soldering.
- B) When soldering, do not load stress on the LEDs during heating.
- C) Never take next process until the component is cooled down to room temperature after reflow.
- D) After soldering, do not warp the circuit board.
- E) The recommended reflow soldering profile (measuring on the surface of the LED resin) is the following:

(a) Lead-Free Solder

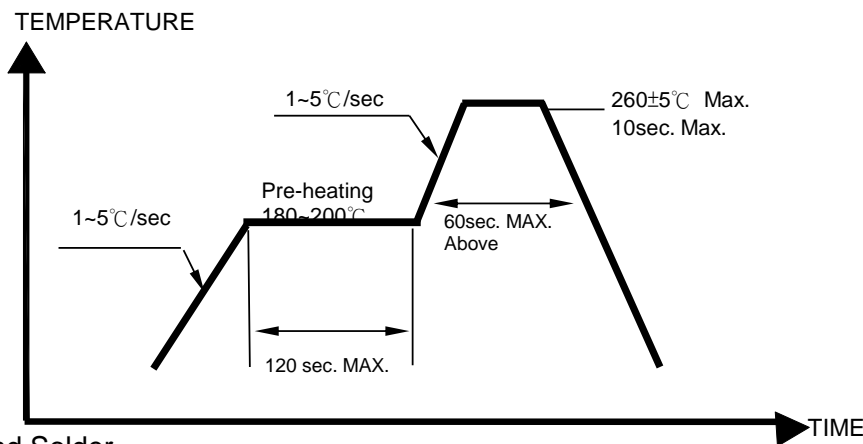

(b) Lead Solder

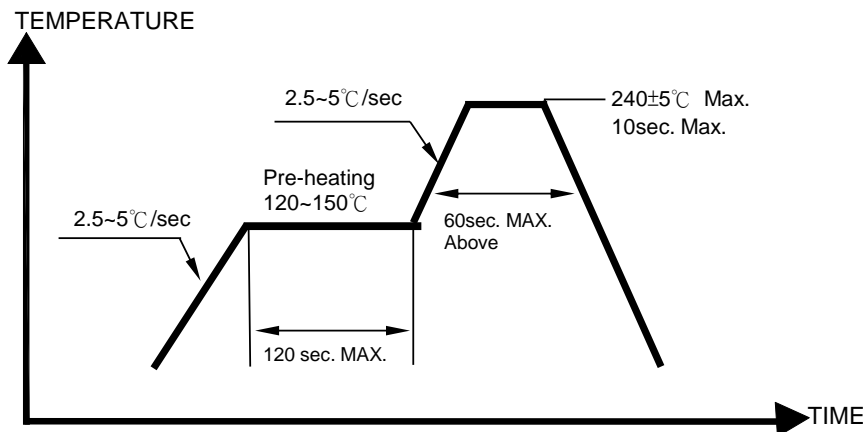

Manual Soldering (not recommended) :

- A) To prevent from cracking, please bake (65°C , 24hrs) before soldering.
- B) Temperature at tip of iron: 250°C Max. (25W).
- C) It's banned to load any stress on the resin during soldering.
- D) Soldering time: 3 sec. Max. (one time only).

Unilite Opto Technology

email: info@unilite-tech.com

U-P3528R-HRF

- (6) ESD (electrostatic discharge) protection (base on machine mode)
- A) The product is AlGaInP based light emitting diode (LED) and is extremely sensitive to ESD. Users are strongly recommended to take necessary meter to test the static electricy and avoid ESD when handling this product.
 - B) Proper grounding of machines (via $1M\Omega$), using static dissipative mats, containers, working uniforms and shoes are considered to be effective against ESD.
 - C) An ionizer is recommended in the facility or environment where ESD may be generated easily, and soldering iron with a grounded tip is also recommended.
 - D) When inspecting the final products in which LEDs are assembled, it is recommended to check whether the assembled LEDs are damaged by ESD or not. It is simple to find damaged LEDs by light-on or VF test at lower current (below 1mA is recommended).
 - E) ESD damaged LEDs will show some unusual characteristics such as the remarkable increasing of leak current, the decreasing of forward voltage, or the LEDs do not light on at the low current.
- (7) Other
- A) Care must be taken to ensure that the reverse voltage will not exceed the absolute maximum rating when using the LEDs with matrix drive.
 - B) The LED light output is strong enough to injure human eyes. Precaution must be taken to prevent looking directly at the LEDs with unaided eyes for more than a few seconds.
 - C) The LEDs described here are intended to be used for ordinary electronic equipment, please consult Unilite Opto in advance for information on applications.
 - D) Installing a protection device in the LED driving circuit to avoid surge current exceeding the max rating during on/off switching.
 - E) The appearance and specifications of the product may be modified for improvement without notice.
 - F) Please use the product within 168 hours after opening the seal and keep under 30 °C and 70% humidity.
 - G) Unilite Opto Technology will not be responsible for any claim for damage if the user use the product without following the caution or instruction of the specification.